

Product Description

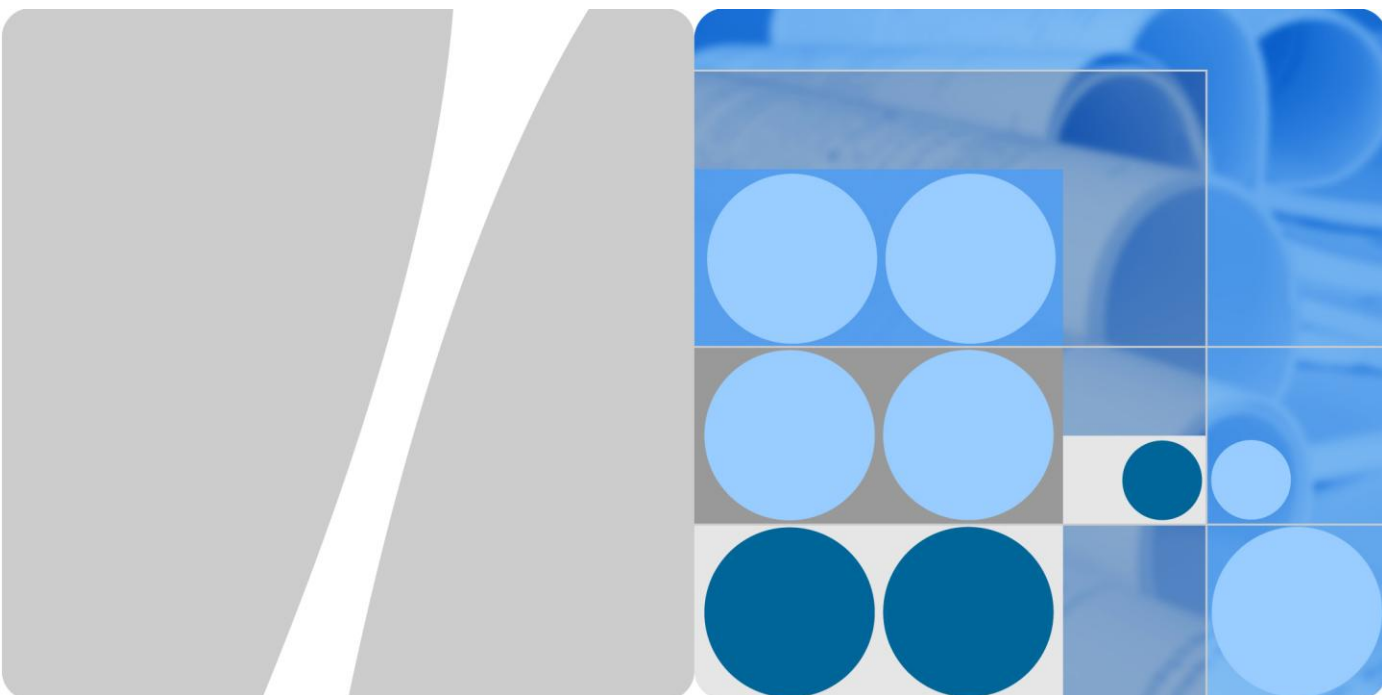

HUAWEI E392 LTE USB Stick

Issue 01
Date 2011-5-03

HUAWEI TECHNOLOGIES CO., LTD.



Huawei Technologies Co., Ltd. provides customers with comprehensive technical support and service. Please feel free to contact our local office or company headquarters.

Huawei Technologies Co., Ltd.

Address: Huawei Industrial Base
Bantian, Longgang
Shenzhen 518129
People's Republic of China

Website: <http://www.huawei.com>

Email: support@huawei.com

Copyright © Huawei Technologies Co., Ltd. 2011. All rights reserved.

No part of this document may be reproduced or transmitted in any form or by any means without prior written consent of Huawei Technologies Co., Ltd.

Trademarks and Permissions



HUAWEI and other Huawei trademarks are trademarks of Huawei Technologies Co., Ltd.

All other trademarks and trade names mentioned in this document are the property of their respective holders.

Notice

The information in this document is subject to change without notice. Every effort has been made in the preparation of this document to ensure accuracy of the contents, but all statements, information, and recommendations in this document do not constitute the warranty of any kind, express or implied.

About This Document

Summary

This document provides information about the major functions, supported services, system architecture, and technical references of HUAWEI E392 LTE USB Stick (hereinafter referred to as the E392).

The following table lists the contents of this document.

Chapter	Describes
1 Overview	The supported network modes, basic services and functions, and the appearance of the E392.
2 Features	The supported features and technical specifications of the E392.
3 Services and Applications	The services and applications of the E392.
4 System Architecture	The architecture of the E392.
5 Technical Reference	The technical references of the E392.
6 Packing List	The items contained in the package of the E392.
A Acronyms and Abbreviations	The acronyms and abbreviations mentioned in this document.



History

Issue	Details	Date	Author	Approved by
01	Initial draft completed.	2011-5-03	E392 Team	Zhou Taotao

Contents

1 Overview	5
2 Features	6
2.1 Main Features	6
Technical Specifications	7
2.1.1 Hardware	7
2.1.2 Dashboard	10
3 Services and Applications	12
3.1 Packet Data Service	12
3.2 SMS	12
4 System Architecture	13
4.1 System Architecture	13
4.2 Functional Modules	14
5 Technical Reference	15
5.1 Layer 1 Specifications (Physical)	15
5.2 Layer 2 Specifications (MAC/RLC)	15
5.3 Layer 3 Specifications (RRC)	16
5.4 Layer 3 NAS/Core Network (MM/CM)	16
5.5 GSM Protocol Specifications	16
5.6 GPRS Protocol Specifications	16
5.7 General Specifications	17
5.8 Performance/Test Specifications	17
5.9 SIM Specifications	17
6 Packing List	18

1 Overview

The E392 supports the following standards:

- Long Term Evolution (LTE)
- High-speed packet access (HSPA+)
- Universal Mobile Telecommunications System (UMTS)
- Enhanced data rates for global evolution (EDGE)
- General packet radio service (GPRS)
- Global system for mobile communications (GSM)

The E392 provides the following services:

- LTE packet data service
- HSPA+ packet data service
- HSUPA packet data service
- HSDPA/UMTS packet data service
- EDGE/GPRS packet data service
- WCDMA/GSM Short Message Service (SMS)
- Prepared for LTE Short Message Service (SMS) over SGs, but not activated.

You can connect the E392 with the USB interface of a computer. In the service area of the LTE/HSPA+/UMTS/EDGE/GPRS/GSM network, you can surf the Internet and send/receive messages/emails cordlessly. The E392 is fast, reliable, and easy to operate. Thus, mobile users can experience many new features and services with the E392. These features and services will enable a large number of users to use the E392 and the average revenue per user (ARPU) of operators will increase substantially.

Figure 1-1 shows the profile of the E392.



Figure 1-1 E392 profile

2 Features

2.1 Main Features

The E392 mainly supports the following features:

- LTE 2600MHz/2100MHz/1800MHz/900MHz/DD800MHz, DC-HSPA+/HSPA+/UMTS 2100MHz/1800MHz/900MHz, GSM/GPRS/EDGE 850MHz/900MHz/1800MHz/1900MHz
- Support LTE 2600 10M/20M bandwidth
- Support LTE 2100 5M/10M bandwidth
- Support LTE 1800 15M/20M bandwidth
- Support LTE 900 5M/10M bandwidth
- Support LTE DD800 5M/10M bandwidth
- LTE 2x2 MIMO
- LTE uplink data service of up to 50Mbps
- LTE downlink data service of up to 100Mbps
- HSPA+ data service of up to 42Mbps(Dual carrier)
- HSDPA/HSPA+ Equalizer and receive diversity(TYPE 3)
- HSPA+ data service of up to 21Mbps(64QAM)
- HSUPA data service of up to 5.76Mbps
- HSDPA data service of up to 14.4Mbps
- UMTS PS domain data service of up to 384 kbps
- EDGE packet data service of up to 296kbps on DL with MSC33
- GPRS packet data service of up to 85.6 kbps
- CS domain data service based on UMTS and GSM
- SMS based on CS/PS domain of GSM and WCDMA
- WCDMA/GSM SMS service
- Prepared for LTE SMS over SGs service, but not activated
- Support LTE intra-frequency handover, inter-frequency handover will be supported by firmware upgrade later
- Support LTE and UMTS inter-RAT idle mobility, LTE and GERAN inter-RAT idle mobility will be supported by firmware upgrade later

- Inter-RAT connected mobility will be supported by firmware upgrade later
- Automatic installation
- Standard USB interface (Type A)
- Micro SD card Slot
- External antenna interface
- Windows XP SP2/SP3, Windows Vista SP1/SP2, Windows 7, Mac OS X 10.5, 10.6 with latest upgrades

Technical Specifications

2.1.1 Hardware

Table 2-1 lists the hardware specifications.

Table 2-1 Hardware specifications

Item	Specifications
Technical standard	LTE Rel 8 WCDMA Rel '99 plus, HSDPA Rel 5, HSUPA Rel 6, HSPA+(cat 18) Rel 7, DC-HSPA+(cat 24) Rel 8 GSM/GPRS/EDGE UMTS Rel 8 Feature: Support 64QAM Support multi cell Support UTRA CELL_PCH/URA_PCH to EUTRA RRC_IDLE cell reselection Support absolute priority based cell re-selection in UTRAN Support cell-specific TX diversity configuration for dual-cell operation

Item	Specifications
Operating frequency	LTE 2600MHz: 2500MHz~2570MHz (Uplink)/2620MHz~2690MHz (Downlink) LTE/WCDMA/HSPA+ 2100MHz: 1920MHz~1980MHz (Uplink)/2110MHz~2170MHz (Downlink) LTE/WCDMA/HSPA+ 1800MHz: 1710MHz~1785MHz (Uplink)/1805MHz~1880MHz (Downlink) LTE/WCDMA/HSPA+ 900MHz: 880MHz~915MHz (Uplink)/925MHz~960MHz (Downlink) LTE DD800MHz: 832MHz~862MHz (Uplink)/791MHz~821MHz (Downlink) GSM/GPRS/EDGE 1900MHz: 1850MHz~1910MHz (Uplink)/1930MHz~1990MHz (Downlink) GSM/GPRS/EDGE 1800MHz: 1710MHz~1785MHz (Uplink)/1805MHz~1880MHz (Downlink) GSM/GPRS/EDGE 900MHz: 880MHz~915MHz (Uplink)/925MHz~960MHz (Downlink) GSM/GPRS/EDGE 850MHz: 824MHz~849MHz (Uplink)/869MHz~894MHz (Downlink)
External interfaces	USB 2.0 High Speed
	SIM/USIM card: standard 6-pin SIM card interface
	Micro SD card Slot
	External antenna interface
Maximum transmitter power	LTE 2600MHz/2100MHz/1800MHz/900MHz/DD800MHz: (Power Class 3)
	WCDMA/HSPA+ 2100MHz/1800MHz/900MHz: (Power Class 3)
	GSM/GPRS 850MHz/900MHz: (Power Class 4)
	GSM/GPRS 1800MHz/1900MHz: (Power Class 1)
	EDGE 850MHz/900MHz:(Power Class E2)
	EDGE 1800MHz/1900MHz: (Power Class E2)
Static receiver sensitivity	LTE 2600MHz/2100MHz/1800MHz/900MHz/DD800MHz: Compliant with 3GPP TS 36.101(R8/R9)
	WCDMA/HSPA+ 2100MHz/1800MHz/900MHz: Compliant with 3GPP TS 25.101(R7)
	GSM/GPRS/EDGE 850MHz/900MHz/1800MHz/1900MHz: Compliant with 3GPP TS 05.05 (R99)

Item	Specifications
TRP	LTE 2600MHz/2100MHz/1800MHz/900MHz/DD800MHz TRP :TBD
	UMTS 2100MHz/1800MHz/900MHz TRP: TBD
	GSM850MHz TRP: TBD
	GSM900MHz TRP: TBD
	DCS1800MHz TRP: TBD
	PCS1900MHz TRP: TBD
TIS	LTE 2600MHz/2100MHz/1800MHz/900MHz/DD800MHz TRS: TBD
	UMTS 2100MHz/1800MHz/900MHz TRS: TBD
	GSM850MHz TRS: TBD
	GSM900MHz TRS: TBD
	DCS1800MHz TRS: TBD
	PCS1900MHz TRS: TBD
Maximum power consumption	<4W
Power supply	4.75V-5.25V / 800mA
LED	<p>indicating the status of the E392</p> <p>No attached to network: green LED blinks twice</p> <p>Attached to GERAN: Green LED blinks once</p> <p>Traffic on GERAN: Green LED lights fixed</p> <p>Attached on WCDMA: Blue LED blinks once</p> <p>Traffic on WCDMA: Blue LED lights fixed</p> <p>Traffic on HSPA+: Cyan LED lights fixed</p> <p>Attached on LTE: Cyan LED blinks once</p> <p>Traffic on LTE: Cyan LED lights fixed.</p>
Dimensions (D x W x H)	100mm x 35mm x 13.8mm
Weight	<40g
Temperature	<ul style="list-style-type: none"> • Operating: -10°C to +40°C • Storage: -20°C to +70°C

Item	Specifications
Humidity	5% to 95%
Notes: LTE = Long Term Evolution 3GPP = The 3rd Generation Partnership Project EGPRS = enhanced GPRS LED = light-emitting diode MSC = mobile switching center SIM = subscriber identity module TS = technical specification USIM = UMTS subscriber identity module	

2.1.2 Dashboard

Two types of dashboards are available, the Windows dashboard and Mac dashboard. The following table takes Windows dashboard as an example.

Table 2-2 lists the dashboard specifications.

Table 2-2 Dashboard specifications

Item	Description
SMS	Writing/Sending/Receiving
	Sending/Receiving extra-long messages
	Group sending
	Storage: The messages are saved in the hard disk of the PC.
	Sorting
	New message prompt (visual prompt/audio prompt)
Flow display and statistics (data services)	Current connection: <ul style="list-style-type: none"> • Duration • Send/Receive flow • Send/Receive rate
	Traffic statistics
Phonebook	Capacity: It depends on the SIM/USIM card capacity or the hard disk space.

Item	Description
	Messages can be sent from the phonebook.
	Importing/Exporting: Import/Export contacts between the SIM/USIM card and a laptop or a file of supported formats.
Network connection setup	<ul style="list-style-type: none"> • APN management • Set up network connection
Software installation	Automatic installation
Other	Network connection settings: <ul style="list-style-type: none"> • Automatic network selection and registration • Manual network selection and registration
	Network status display: signal, operator name, system mode, and so on.
	Selection of network connection types.
	PIN management: activate/deactivate PIN, PIN lock, changing PIN, unblocking by using the PUK.
System requirement	<ul style="list-style-type: none"> • Windows XP SP2/SP3, Windows Vista SP1/SP2, Windows 7 • Mac OS X 10.5 and 10.6 with latest upgrades • Your computer's hardware system should meet or exceed the recommended system requirements for the installed version of OS • Display resolution: 800 × 600 or above
Notes: PIN = personal identification number PUK = PIN unblocking key	

3 Services and Applications

3.1 Packet Data Service

The E392 supports the PS domain data service based on LTE/HSPA+/UMTS /EDGE/GPRS

After you connect the E392 to a PC with the USB interface, the E392 driver and the client software are installed on the PC automatically. Dual APN is supported in LTE mode. A default APN will be used at initial attach to LTE. The other APN is use like normal APN in 2G/3G. You can configure APN through the E392 application (or directly use the default settings) and set up a network connection. Then you can send or receive E-mail, access the network through wireless connection, and download files through wireless data channels.

To use the data service, perform the following steps:

1. Enter ***99#** or ***98#** to launch the packet data service.
2. In the **Choose Connection Type** dropdown box, choose a network type.

3.2 SMS

The E392 supports message writing/sending/receiving and group sending on GSM/EGDE/UMTS network. As long as SMS over SGs is not activated for LTE, so no messages can be sent/or received on LTE, and the messages can only be stored. You can manage messages through the dashboard, such as sorting the messages by telephone number or time.

4 System Architecture

4.1 System Architecture

Figure 4-1 shows the system architecture.

Figure 4-1 System architecture

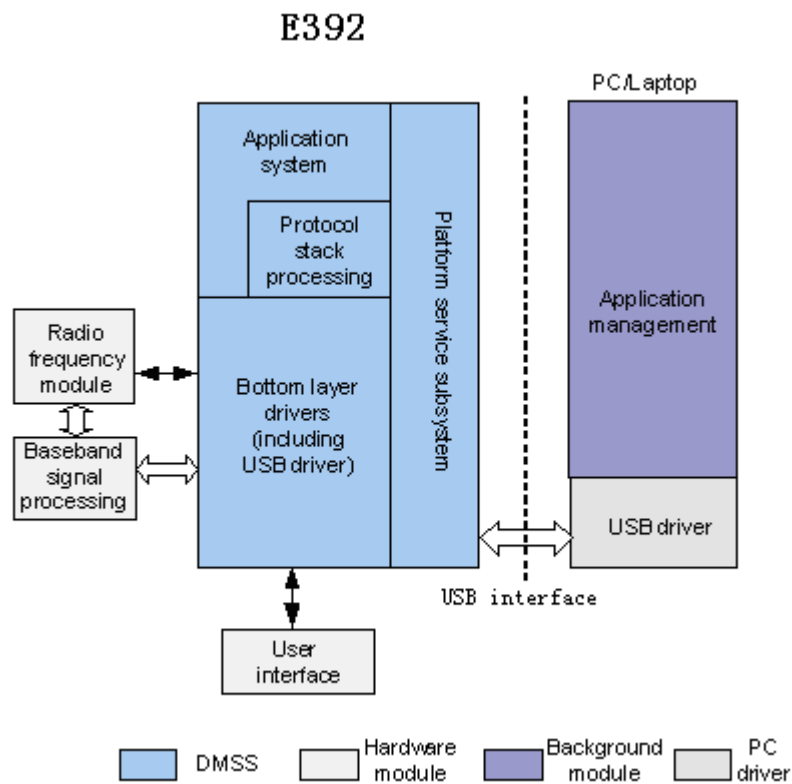

4.2 Functional Modules

Radio Frequency Module

It sends/receives radio signals and modulates/demodulates the radio frequency (RF) signals and baseband signals.

Baseband Signal Processing

It processes LTE/HSPA+/UMTS/EDGE/GPRS/GSM baseband digital signals, including:

- Modulating/Demodulating LTE baseband signals
- Modulating/Demodulating HSPA+/UMTS baseband signals
- Modulating/Demodulating EDGE/GPRS/GSM baseband signals
- Encoding/Decoding HSPA+/UMTS channel
- Encoding/Decoding EDGE/GPRS/GSM channel

Bottom Layer Driver

It drives peripherals, including USB, LED, Micro-SD and SIM/USIM.

Platform Service Subsystem

It initializes programs, diagnoses the running of the system, downloads data and serves as a watchdog.

Protocol Stack System

It processes protocols of LTE/HSPA+/UMTS/EDGE/GPRS/GSM.

Application System

It sends laptop commands to the bottom layer protocol for processing and returns the value to the laptop.

Existing applications include the following:

- Call management
- Message management
- CS/PS domain service management

User Interface

It provides interfaces to connect peripherals. Interfaces are USB (type A), External Antenna, Micro-SD and SIM/USIM.

Application Management

Through the application window, you can set the parameters of the E392 and operate the E392.

5 Technical Reference

5.1 Layer 1 Specifications (Physical)

- Examples of Channel Coding and Multiplexing TR 25.944
- Physical Layer–General Description TS 25.201
- Physical Channels and Mapping of Transport Channels onto Physical Channels (FDD) TS 25.211
- Multiplexing and Channel Coding (FDD) TS 25.212
- Spreading and Modulation (FDD) TS 25.213
- Physical Layer–Procedures (FDD) TS 25.214
- Physical Layer–Measurements (FDD) TS 25.215
- 3GPP HSDPA overall description 25.308
- 3GPP UE radio access capabilities 25.306
- LTE Physical Layer - General Description 36.201 R8
- E-UTRAN Physical Channels and Modulation 36.211
- E-UTRAN Multiplexing and channel coding 36.212
- E-UTRAN Physical layer procedures 36.213
- E-UTRAN Physical layer – Measurements 36.214
- E-UTRAN Services provided by the physical layer 36.302

5.2 Layer 2 Specifications (MAC/RLC)

- MAC Protocol Specification TS 25.321
- RLC Protocol Specification TS 25.322
- E-UTRAN Layer 2 – Measurements 36.314
- E-UTRAN Medium Access Control (MAC) protocol specification 36.321
- E-UTRAN Radio Link Control (RLC) protocol specification 36.322
- E-UTRAN Packet Data Convergence Protocol (PDCP) specification 36.323

5.3 Layer 3 Specifications (RRC)

- UE Interlayer Procedures in Connected Mode TS 25.303
- UE Procedures in Idle Mode TS 25.304
- RRC Protocol Specification TS 25.331
- E-UTRAN Radio Resource Control (RRC) Protocol specification 36.331
- E-UTRAN User Equipment (UE) procedures in idle mode 36.304

5.4 Layer 3 NAS/Core Network (MM/CM)

- Architectural Requirements for Release 1999 TS 23.121
- NAS Functions Related to Mobile Station (MS) in Idle Mode TS 23.122
- Mobile Radio Interface Signaling Layer 3–General Aspects TS 24.007
- Mobile Radio Interface Layer 3 Specification–Core Network TS 24.008
- PP SMS Support on Mobile Radio Interface TS24.011
- Non-Access-Stratum (NAS) protocol for Evolved Packet System (EPS) 24.301

5.5 GSM Protocol Specifications

- Mobile Radio Interface Layer 3 Specification, Radio Resource Control Protocol TS 04.18
- Mobile Station–Base Station System (MS–BSS) interface; Data Link (DL) Layer Specification TS 04.06
- Digital Cellular Telecommunications System (Phase 2+); Multiplexing and Multiple Access on the Radio Path TS 05.02
- Technical Specification Group GERAN; Channel coding TS 05.03
- Digital Cellular Telecommunications System (Phase 2+); Radio Subsystem Link Control TS 05.08
- Digital Cellular Telecommunications System (Phase 2+); Radio Subsystem Synchronization TS 05.10

5.6 GPRS Protocol Specifications

- Overall Description of the GPRS Radio Interface; stage 2 TS 3.64
- Mobile Radio Interface Layer 3 Specification TS 04.08
- Mobile Radio Interface Layer 3 Specification: Radio Resource Control Protocol TS 04.18
- General Packet Radio Service (GPRS): Mobile Station (MS)–Base Station System (BSS) interface; Radio Link Control/Medium Access Control (RLC/MAC) protocol TS 04.60
- Mobile Station–Serving GPRS Support Node (MS–SGSN) Logical Link Control (LLC) Layer Specification TS 04.64

- Mobile Station–Serving GPRS Support Node (MS–SGSN); Subnetwork Dependent Convergence Protocol (SNDCCP) TS 04.65
- Multiplexing and Multiple Access on the Radio Path TS 05.02
- Channel Coding TS 05.03
- Modulation TS 05.04
- Radio Transmission and Reception TS 05.05
- General Packet Radio Service (GPRS); Stage 1 TS 22.060
- Mobile Execution Environment (MexE) TS 23.057
- General Packet Radio Service (GPRS) Service description; stage 2 TS 23.060

5.7 General Specifications

- UE Capability Requirements TR 21.904
- UE Radio Access Capabilities TR 25.926
- Vocabulary TR 25.990
- Radio Interface Protocol Architecture TS 25.301
- Services Provided by the Physical Layer TS 25.302
- Synchronization in UTRAN Stage 2 TS 25.402

5.8 Performance/Test Specifications

- User Equipment (UE) Conformance Specification; Radio transmission and reception TS 36.521
- User Equipment (UE) conformance specification; Part 1: Protocol conformance specification TS 36.523-1
- UE Radio Transmission and Reception (FDD) TS 25.101
- Common Test Environments for User Equipment (UE) TS 34.108
- Special Conformance Testing Functions TS 34.109
- Terminal Conformance Specification TS 34.121
- User Equipment (UE) Conformance Specification; Part 1: Protocol Conformance TS 34.123-1
- User Equipment (UE) Conformance Specification; Part 2: Protocol Conformance TS 34.123-2

5.9 SIM Specifications

- SIM and IC Card Requirements TS 21.111
- 3rd Gen. Partnership Proj Tech. Spec. Group Terminals; SIM App. Toolkit (USAT) TS 31.111
- 3rd Generation Partnership Project .Technical Specification Group Core Network and Terminals ;Characteristics of the Universal Subscriber Identity Module (USIM) application TS 31.102

6 Packing List

This chapter describes the items contained in the package of the E392.

Table 6-1 lists the items contained in the package of the E392.

Table 6-1 Packing list of the E392

Item	Quantity	Remarks
HUAWEI E392 LTE USB Stick	1	Standard
HUAWEI E392 LTE USB Stick Quick Start	1	Standard

A Acronyms and Abbreviations

3GPP	3rd Generation Partnership Project
APN	Access Point Name
ARPU	Average Revenue Per User
BSS	Base Station Subsystem
CM	Connection Management
CS domain	Circuit Switched domain
EDGE	Enhanced Data Rates for GSM Evolution
EGPRS	Enhanced GPRS
FDD	Frequency Division Duplex
GERAN	GSM/EDGE Radio Access Network
GPRS	General Packet Radio Service
GSM	Global System for Mobile Communications
HSPA+	High-Speed Packet Access
HSUPA	High-Speed Uplink Packet Access
HSDPA	High-Speed Downlink Packet Access
LED	Light Emitting Diode
LTE	Long Term Evolution
MAC	Medium Access Control
MexE	Mobile Execution Environment
MM	Mobility Management
Modem	Modulator Demodulator
MS	Mobile Station
MSC	Mobile Switching Center

NAS	Non-Access Stratum
OS	Operating System
PC/SC	Personal Computer/Smart Card
PIN	Personal Identification Number
PnP	Plug and Play
PP	Point-to-Point
PS domain	Packet Switched domain
PUK	PIN Unblocking Key
RF	Radio Frequency
RLC	Radio Link Control
RRC	Radio Resource Control
SGSN	Serving GPRS Support Node
SIM	Subscriber Identity Module
SMS	Short Messaging Service
SNDCP	Subnetwork Dependent Convergence Protocol
TR	Technical Report
TS	Technical Specification
UE	User Equipment
UMTS	Universal Mobile Telecommunications System
USAT	USIM Application Toolkit
USB	Universal Serial Bus
USIM	UMTS Subscriber Identity Module
UTRAN	UMTS Terrestrial Radio Access Network
WCDMA	Wideband Code Division Multiple Access